

# Eclipse InciniFume Burners

High Temperature Raw Gas Burner

Model VAI

Version 1.0

## Main Specifications

PARAMETER	DESCRIPTION
Maximum input in Btu/hr (kW)*	
-Straight (300mm)	850,000 (250)
-Tee (300mm x 150mm)	1,025,000 (300)
-Cross (300mm x 300mm)	1,370,000 (400)
Gas $\Delta P$ in "w.c. (mbar) @ 70°F (21°C)	
-Natural gas	2.4 (6.0)
-Propane	1.0 (2.5)
-Butane	0.8 (2.0)
-Low calorific gases	depends on spec.
% Process O <sub>2</sub> (wet) up-stream (any temperatures)	18 - 21
% Process O <sub>2</sub> (wet) up-stream - above 572°F (300°C)	15 - 21
% Process O <sub>2</sub> (wet) down-stream	12 minimum
Process Temperatures	
Maximum up-stream air temp. °F (°C)	1200 (650)
Maximum down-stream air temp. °F (°C)	1750 (950)
Air $\Delta P$ across burner in "w.c. (mbar)	0.4 - 1.0 (1.0 - 2.5)
Process velocity across the burner in fpm (m/s)	2000 - 6000 (10-30)
Flame Length in inches (mm)	39-100 (1000-2500) Depending on process velocity
Emissions	Dependent on application and temperatures
Process air distribution requirements	+/- 15% in velocity across burner
Flame monitoring**	UV scanner only (cooled)
Rear gas feed availability	
- Straight	Yes
- Tee	No
- Cross	Yes
Burner Shadow Area sq. in. (cm <sup>2</sup> )	
-Straight (300mm)	73 (470)
-Tee (300mm x 150mm)	85.3 (550)
-Cross (300mm x 300mm)	97 (625)

\* Higher inputs may be possible depending on application, inlet temperatures, oxygen content and velocities. Contact Eclipse with questions.

\*\*Burners over 5 lineal feet require flame supervision at the far end. If pilot ignition is used, two flame supervision units are required; one for pilot and one for far end. If using direct spark on the main flame, only flame supervision on the far end is required providing ignition can be accomplished within 15 seconds. (Local regulations must be followed.)

- Contact Eclipse for an estimate on data for non-standard conditions.
- All inputs based on net calorific values and standard conditions: One Atmosphere, 70° F (21° C).

### Reference Data

Fuel Type	MJ/Nm <sup>3</sup>	Btu/cu.ft.	d /s.g.
Natural gas	39	1050	0.6
Propane	93	2500	1.5
Butane	123	3200	2.0

## Capacities

### Gas ΔP vs Input

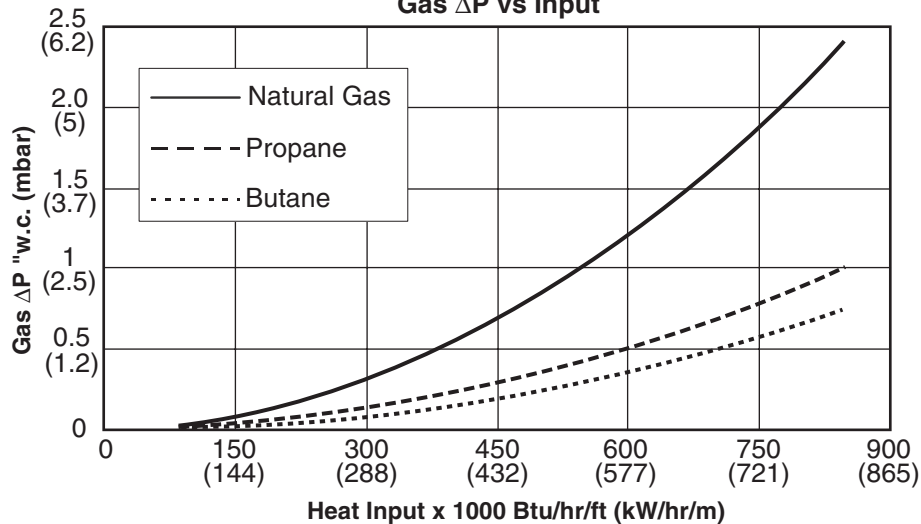

- 1.) Gas ΔP measured from gas inlet of burner to 20" (508mm) downstream of the burner.
- 2.) ΔP's will rise per input with increase in gas temperature.

### Inlet Air Temperature Correction

<i>Air Press. Drop @ Air Temp. = Air Press. Drop (@ 70° F (21° C) x Correction Factor</i>								
<b>Air Inlet Temp. °C</b>	260	316	371	427	482	538	593	650
<b>Air Inlet Temp. °F</b>	500	600	700	800	900	1000	1100	1200
<b>Correction Factor</b>	1.81	2.0	2.19	2.37	2.56	2.75	2.95	3.13

## General Information

### Introduction

The Eclipse VAI burner belongs to the "Air Heat Family" of burners. It is designed for high temperature process air heating applications such as supplementary firing in cogeneration systems, dryers, incinerators and ovens. The VAI design provides stable operation over a wide range of velocities, inputs and fuels.

### Description

The VAI burners are constructed of stainless steel bodies and diverging air wings made of Avesta 253MA. The burner bodies supply fuel to the center of the air wings to control the air and fuel mixture inside the burner and optimize efficiency and emissions.

The VAI burner can be assembled from straight sections, tee sections or crosses to produce nearly any configuration required. Large burners can be built as a combination of staged, individually controlled sections to increase turndown.

### Ignition

Direct spark or pilot ignition may be used. The pilot consists of a burner head with ignition plug located outside the burner duct and an extension tube to overcome the distance between the pilot burner and the main burner. The UV scanner is mounted on the pilot burner to prove the pilot flame. A UV scanner port can be provided at the opposite end of the burner. The pilot assembly includes adjustable gas and air valves in order to obtain the required air/gas ratio and flame length. Also, an integrated pilot can be specified and incorporated on each type of module.

### Materials

The burner is completely manufactured from heat resistant materials as specified below.

Burner castings	AISI 347	(Wst I.4550)
Air wings	Avesta 253MA	(Wst I.4835)
Gas Manifolds (If Supplied)	AISI304L/AISI316L	Wst I.4306/I.4404)

### Configuration Design

In high temperature applications requiring long lines or zones use configurations made of crosses for better air wing free expansion.

## Dimensions of Modules in inches (mm)

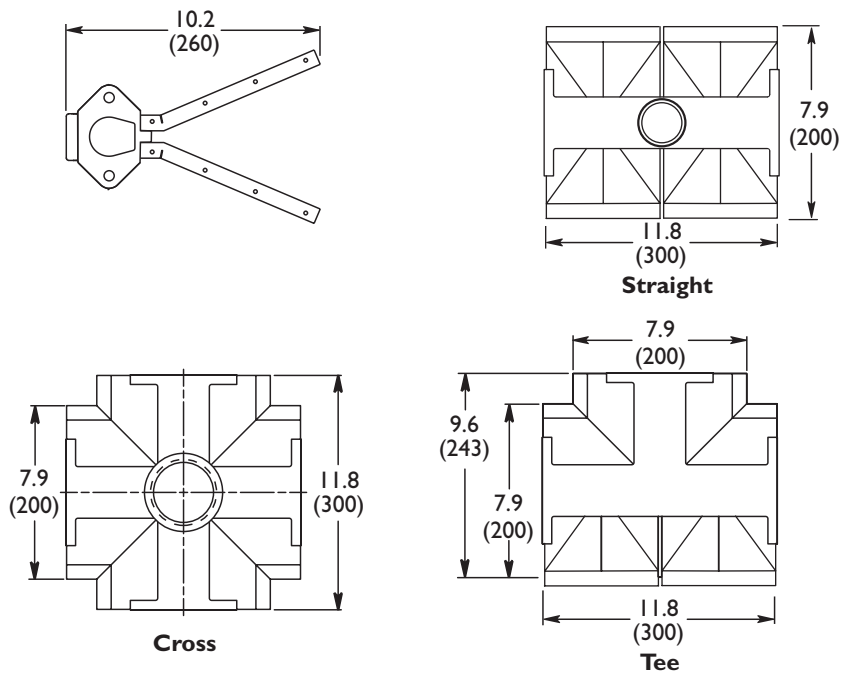

## Configuration Examples

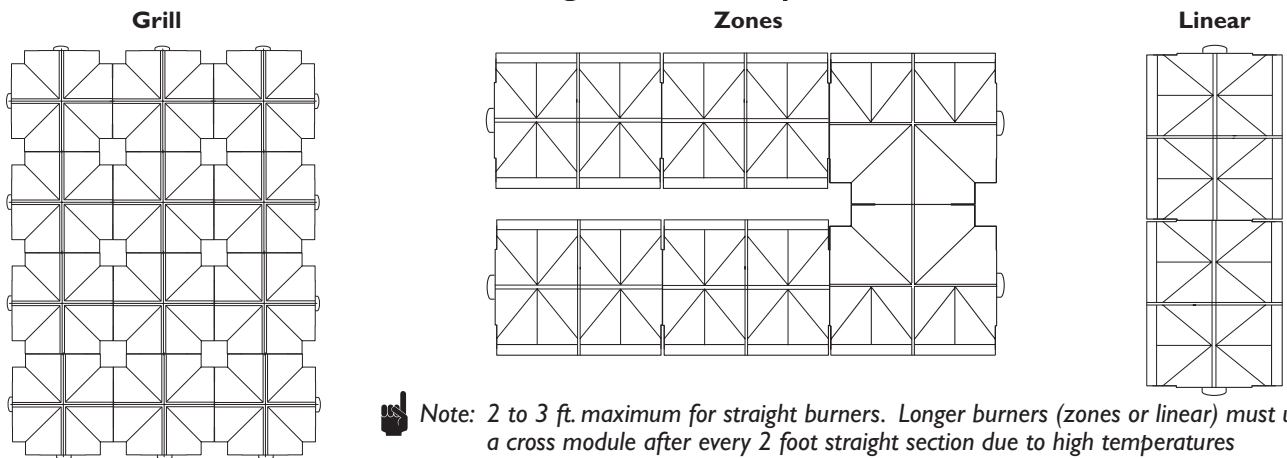

**Note:** 2 to 3 ft. maximum for straight burners. Longer burners (zones or linear) must use a cross module after every 2 foot straight section due to high temperatures

## Profile Plate Location

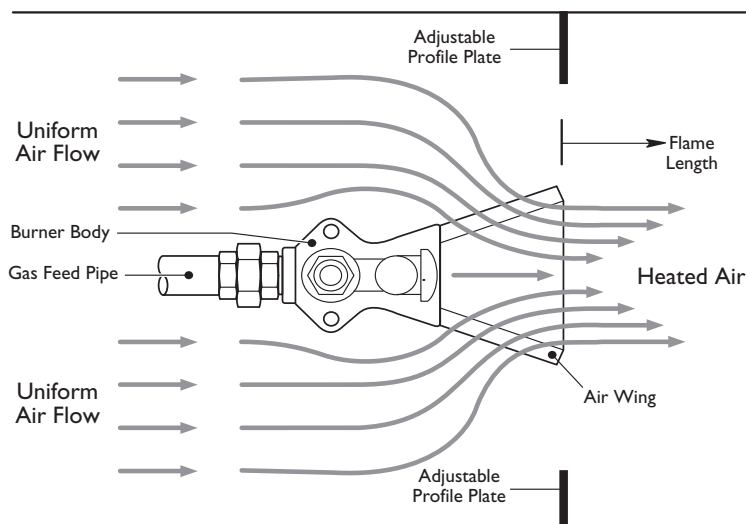



**Offered By:**

Power Equipment Company  
2011 Williamsburg Road  
Richmond, Virginia 23231  
Phone (804) 236-3800  
Fax (804) 236-3882

---

[www.peconet.com](http://www.peconet.com)